

Jonathan Ebersole

Structural Option

Dr. Hanagan

Oklahoma University Children's Medical Office Building

Oklahoma City, Oklahoma

13 December 2013

Proposal



Executive Summary

Oklahoma University Children's Medical Office Building is an office building located in Oklahoma. It is situated next to an existing hospital and parking garage. The building houses offices, examination rooms and labs for the expanding OU Children's Hospital. It is the largest free standing clinical office in the state and provides much needed medical services to the children of Oklahoma and their families. The building is twelve stories tall for a total of 180 feet and is approximately 320,000 gsf.

The structure of the building is reinforced concrete. The building uses a flat slab system supported by columns and exterior beams. Drop panels are used at the column locations to provide extra shear and moment capacity to the slab. The columns are supported on drilled piers that transfer the loads to bedrock underneath the building. The building also uses shear walls and moment frames to resist the lateral forces.

This building provides several unique challenges that a typical office building would not otherwise have. These include a parking garage located on the first floor, a future helicopter pad positioned on the roof, and impact loads on lower levels for vehicle collisions with the building. These design parameters will increase the difficulty of future design assignments as all load cases must be analyzed.

The proposal will include a redesign of the structural system from cast-in-place reinforced concrete to steel with a composite beam action. Composite decking will be used with a concrete topping thick enough to achieve a two hour fire rating. The lateral system will be redesigned using braced frames instead of the existing cast-in-place reinforced concrete shear walls. The redesign of the building will reduce construction time and lower the project costs.

In addition to the design alternative, two breadths will be conducted. These breadths will include an in-depth cost and schedule analysis and a green roof addition. Since the structural system will be change from concrete to steel, the costs and construction times will be decreased and an analysis will be conducted to compare the existing system with the proposed system. A green roof will be added to reduce the heating and cooling costs of the building as well as promote good health for the nearby hospital by reducing the amount of pollution.

Table of Contents

- 1. Introduction – 3
 - 1.1 Scope – 3
 - 1.2 Building Description – 3
- 2. Structural Framing System – 7
 - 2.1 Codes – 7
 - 2.2 Loads – 7
 - 2.3 Foundations – 9
 - 2.4 Typical Bay – 13
 - 2.5 Columns – 14
 - 2.6 Beams – 15
 - 2.7 Slabs – 15
 - 2.8 Lateral System – 16
 - 2.5 Reinforcement – 18
- 3. Structural Design Alternative – 19
- 4. Proposed Solution – 19
- 5. Solution Method – 21
- 6. Tasks and Tools – 22
- 7. Timetable – 24
- 8. Breadth Topics – 25
- 9. Conclusion – 25

Introduction

Scope

The purpose of this report is to give a brief explanation of the building and to propose a solution that changes the structure of the building from cast-in-place concrete to composite steel. Two breadth topics will also be discussed towards the end of the report. The breadth topics will include a cost and schedule analysis as well as a green roof addition.

Building Description

Oklahoma University Children's Medical Office Building is located on 1200 N. Children's Avenue Oklahoma City, Oklahoma between Stanton L. Young Blvd and N.E. 13th Street. Figure A shows the building's location and orientation on the site, highlighted in red. The building is twelve stories above grade and is approximately 180 feet tall. Miles Associates, Inc. designed the building for the University Hospitals Trust to provide additional medical offices for the expanding Oklahoma University Children's Hospital next door. The building is the first free-standing, multi-specialty physicians' office building in the state that will meet the needs of the children of Oklahoma as well as their families.

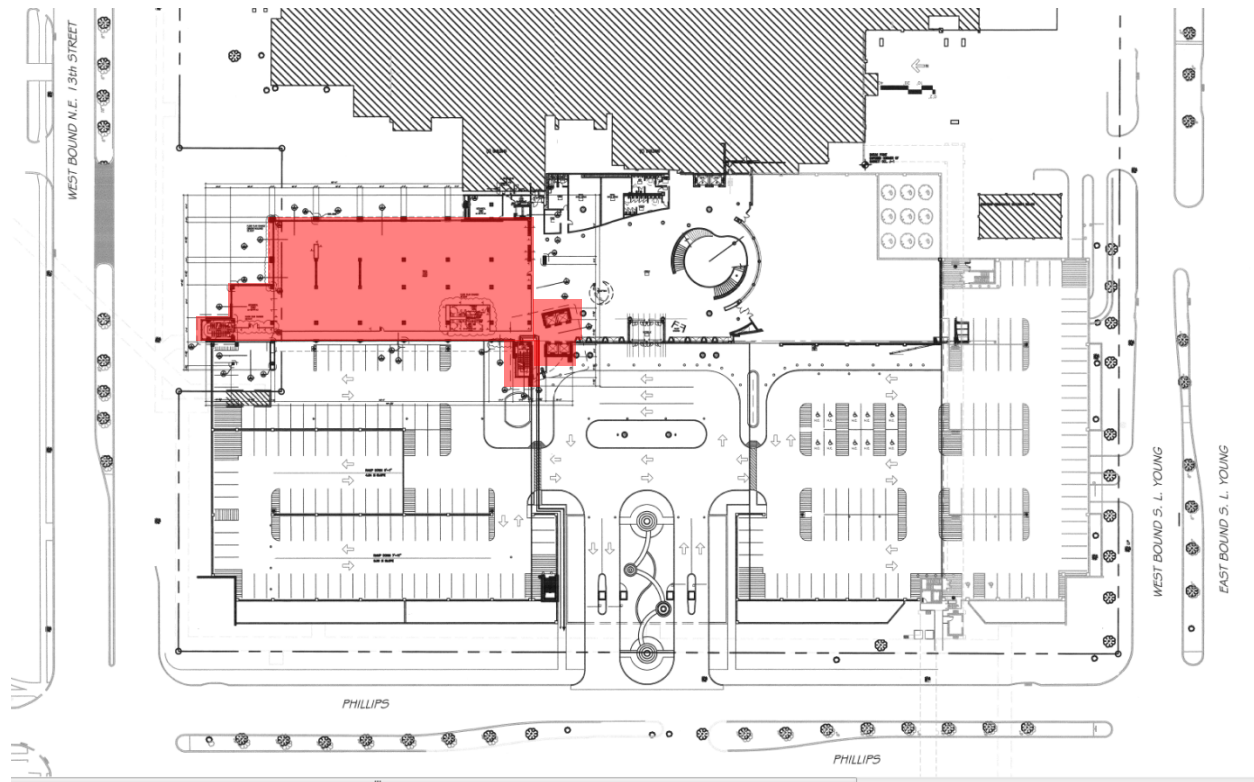

Figure A. Building's location on the site.

The exterior façade of the building is comprised of a brick curtain wall that is accompanied by a large glass curtain wall located on the western side of the building. The glass curtain wall is separated by metal panels at each level change, shown in Figure B. Smaller versions of this curtain wall can also be seen on portions of the North, South, and East elevations to break up the brick façade. To further break up the brick façade on these three elevations, bricks are stacked uniformly on top of one another between windows instead of stacked at an offset like the rest of the building as shown in figure C. The architects also chose to expose concrete columns at certain locations to further add to the appeal of the building. The interior of the building utilizes painted gypsum board for the finish of the walls. The ceiling is composed of acoustical tile as well as gypsum board. The floor types vary from carpet to ceramic tile to sealed concrete, depending on the functionality of the room.

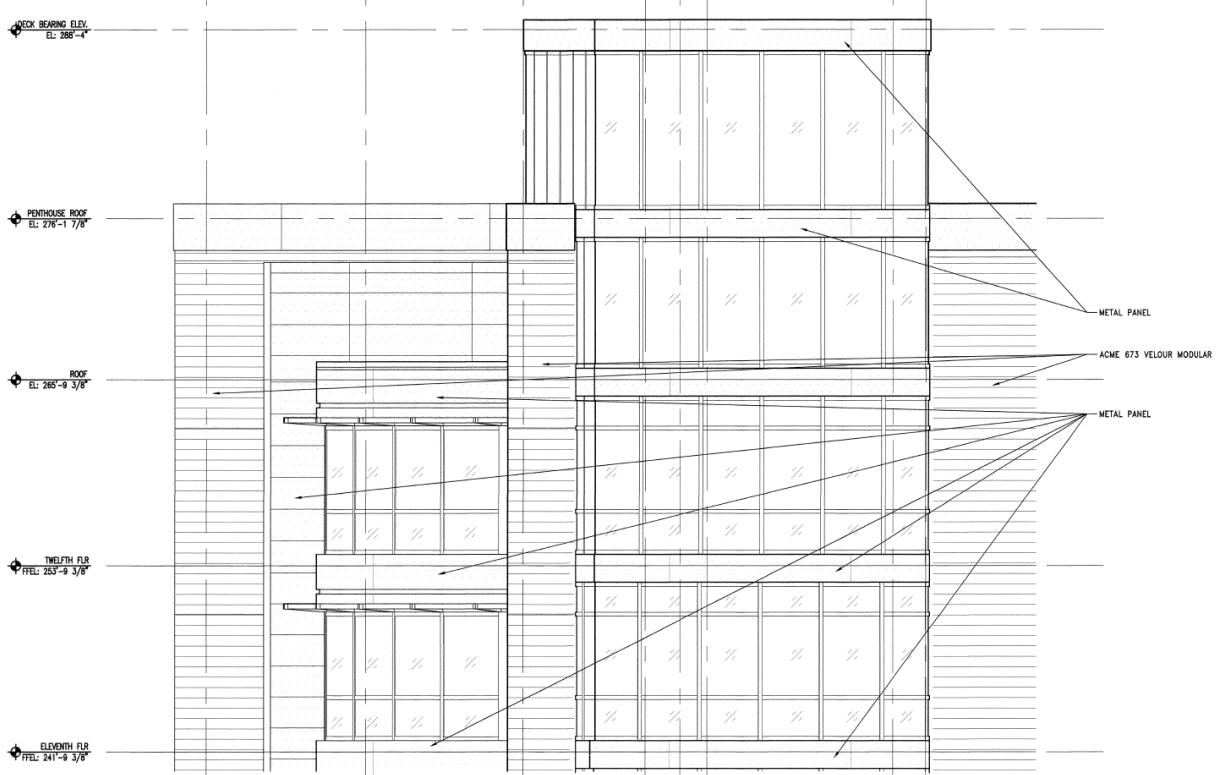

Figure B. Elevation showing the glass curtain wall.

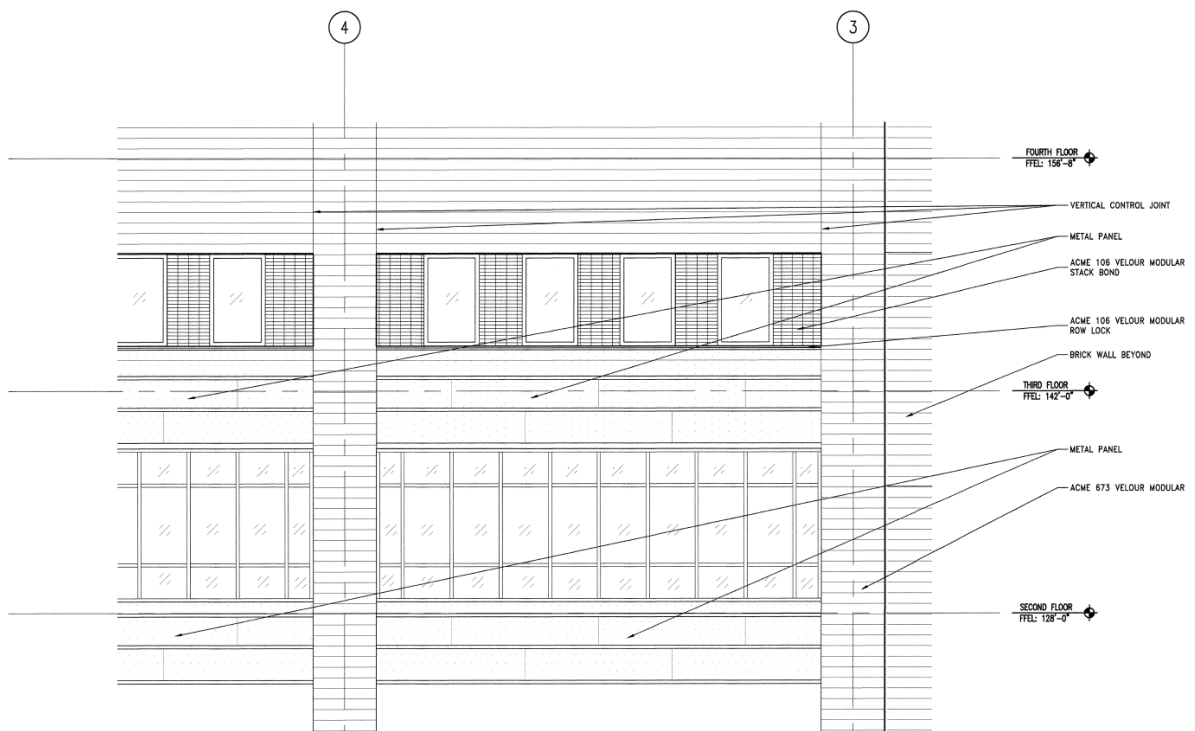

Figure C. Elevation showing brick façade.

The typical floor plan includes various necessities to the Oklahoma University Children’s Medical Office Building that are not typical for other office buildings, such as exam rooms, x-ray rooms, and labs. However, there are similar rooms to the typical office building which include offices, storage rooms, waiting areas, and conference rooms. One challenge that this building possesses is a parking garage occupies the first floor of the building. This challenge will be especially difficult structurally as the basement is to be occupied by offices, exam rooms, and work areas. The typical floor is set up so that an elevator lobby and stairwell is located at the Southwest corner of the building as shown in red in figure D., The lobby leads to a waiting and reception area on the western face of the building and eventually to a stairwell at the northwest corner, shown in yellow. The waiting areas branch out to four rows of corridors with offices and exam rooms on each side, shown in blue. Finally shown in green, the corridors lead to another corridor on the eastern side of the building that runs parallel to the waiting areas. A conference room, shown in purple, is located at the northwest corner of the building. Each floor also contains its own mechanical rooms, shown in brown. This layout allows the building to be easily navigable for new guest and emergency situations. The floor layouts do not differ widely as most have the layout as described above. The only changes are the room types and sizes.



Figure D. Floor plan showing typical rooms and layout.

The building was designed as a conventionally reinforced concrete structure, utilizing concrete columns and beams to resist the gravity loading. The designers chose to use a flat slab system to reduce the amount of interior beams and reduce the floor to floor height. To resist the lateral loads, the designers implemented shear walls located

throughout the building. The foundation uses both concrete piers as well as spread footings in the design.

Structural Framing System

In order to design a safe, functional building, the designers must review the codes to determine the appropriate loading conditions and standards to design the building by. Once the loads are determined, the designer must then understand how to transfer these loads into the ground. Next, the designer can analyze the structure to develop the appropriate sizes for the foundation, columns, beams, and slabs. An analysis for the lateral loads must be completed and the most efficient lateral system must be chosen. Finally the connections and reinforcement must be detailed.

Codes

Since the building was in the design phase in 2006, most of the newer updates of the codes were not released yet. The structural designers instead used the 2003 International Building Code, ASCE 7-02, and the ACI 318-02 codes. The International Building Code describes the live load cases and the general practices a designer should use while designing a building, but does not detail proper procedures for a structural analysis. ASCE 7-02 is used to determine the proper procedures for wind and seismic design. ASCE 7-02 also has factored load cases for dead and live loads as well as snow loads. Since the building is constructed from reinforced concrete, ACI 318-02 provides the proper procedures for designing concrete structures.

Loading

The primary gravity resisting system of the building is the columns, beams, and slabs. This system resists loading that are separated into three categories which are live load, dead load, and snow load. All three of these categories are loads that result from the force of gravity acting on the structure. Live loads are loads that are produced by the use and occupancy of the building. These loads include people and furniture. The loading can vary depending on the occupancy of the building and the room type. The Oklahoma University Children's Medical Office Building is designed as an office occupancy with interior partitions. The International Building Code requires that the minimum loading for an office building is 50 psi for the live loads, however; the designed loading is based on an 80 psf corridor loading to allow flexibility in the floor plan layout. The code standard for the corridor live load is then added to the 20 psf allowance for interior partitions for a total of 100 psf. The stairs and exits are also designed at 100 psf due to a higher occupancy for emergencies, while the mechanical rooms and electric rooms are designed at 125 psf. The roof also sees a live load for maintenance which is a minimum of 20 psf.

Dead loads consist of the weight of all the construction materials that are incorporated into the building. These are much easier to design for as they are known or can be easily approximated. Dead loads include the weight of the structure itself and the weight of mechanical equipment and lights. Typical dead loads are about 2 psf for ceilings and 10 psf for the duct systems, just to name a few.

The third load category is snow loads. This type of loading is caused by snow lying on the roof of the structure. Based on ASCE 7-02, the snow load calculations will be determined based on the criteria of a flat roof since the slope of the roof is less than 5°. ASCE 7-02 suggests that the ground snow load used in the calculations is to be 10 psf for Oklahoma City. In addition to the snow lying on the roof, a drift load must also be incorporated into the load. The snow drift load is the result of wind causing the snow to build up around obstructions on the roof, which adds additional loads to these areas. These obstructions include the helicopter pad, the parapet, stairwells, and elevator mechanical rooms.

OU Children's Medical Office Building has several unique loading cases which include ambulance load, vehicle impact load, and a load for a helicopter pad. One of the design parameters for the building is to have an ambulance bay, which presents another unique loading case. This loading is specified by AASHTO. In addition to the live loads, the building has a vehicle impact load. This load is located 18" above the finish floor and is a 6 kip unfactored load. Due to the proximity of a parking garage, a vehicle impact load must be applied to ensure the stability of the building in the event a column is struck by a vehicle. Another design requirement of the building is for the future installation of a helicopter pad on the roof. This loading is determined by the helicopter pad manufacture.

The load path of the gravity system originates at the roof. The snow loads, roof live loads, and roof dead loads are imposed on the slab, which in the case of this building, are directly transferred to the columns as there are very few interior beams. As the load is transferred from the roof of the building to the foundation, it increases with each floor since the floor loads are now added to the total load. The floor loads are determined by the live and dead loads that are imposed on the slab. The slab then transfers these loads to the columns. For the few interior beams, the loading is transferred from the slab to the beams and into the columns. The perimeter beams are designed to directly transfer the gravity load from the curtain wall to the columns. Once the load reaches the columns, it is then transferred into the foundation, which is comprised of piers and spread footings. Finally the load is transferred from the foundation into ground stable enough to hold the loads.

In addition to gravity loads, the building must also resist forces in a lateral direction. These loads include wind and seismic loading which either push the building (wind) or shake the building (seismic). In the case of wind loads, wind pushes on the exterior

cladding, creating positive pressure on the windward side and negative pressure on the sidewalls, leeward face, and roof. The connections between the cladding and the floor transfer the loading to the diaphragm. The diaphragm is rigidly connected to the shear walls and is transferred into the ground. As the building increases with height, the wind pressure also increases. Similar to wind, seismic forces are a natural phenomenon that results in the lateral movement of a building. Wind is more dependent on the building geometry and topography of the surrounding area; whereas, seismic forces are more dependent on the total weight of the building. This loading is transferred through the soil in a “wave”. The building absorbs this force and responds by swaying back and forth. The building counteracts this swaying via the inertia provided by the shear walls.

Foundations

The foundations receive the loading from the columns and must transfer it onto stable ground. A foundation plan is shown in Figure E. The foundations are comprised of concrete drilled piers underneath the columns, shown in blue, and spread footings under the shear walls in the southwestern corner, shown in red. Areas shown in green have a spread footing underneath the column with a drilled pier under the spread footing.

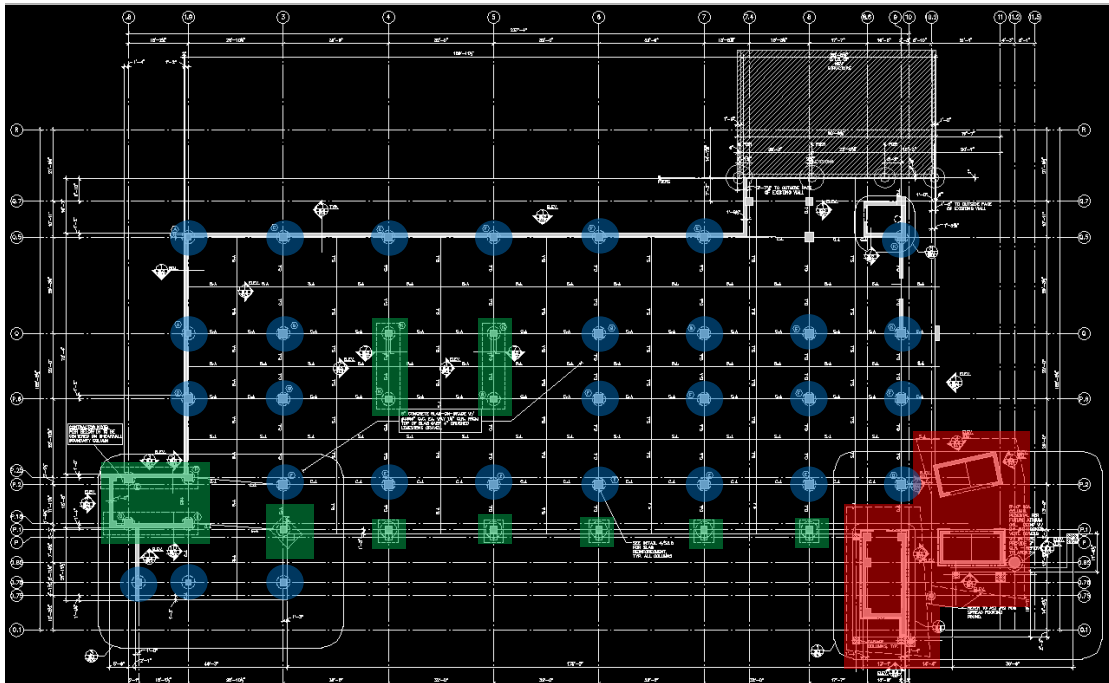

Figure E. Foundation Plan highlighting the footings and drilled piers.

The drilled piers are used to transfer the loading from the columns down into the bedrock. From the geotechnical report, the pier bearing elevation must be below 1195 feet in order

to achieve the maximum bearing capacity. The bottom of pier elevation exceeds the 1195 feet with most at 1190 feet. The lowest elevation is at 1167 feet. The shaft size ranges from 30" in diameter to 72" in diameter. The bearing capacity ranges depending on the pier depth and diameter with the minimum at 679 kips and the maximum at 4307 kips. The reinforcement depends on the diameter. The smallest pier (30" in diameter) uses 8 #6 bars while the largest pier (72" in diameter) uses 21 #9 bars. The ties are typically #5 bars but #3 bars are used for the #6 vertical bars. The spacing for the ties is different depending on the pier and vertical bars. The smallest spacing is 10" on center and largest spacing is 18" on center. Figure F shows a typical detail of a drilled pier.

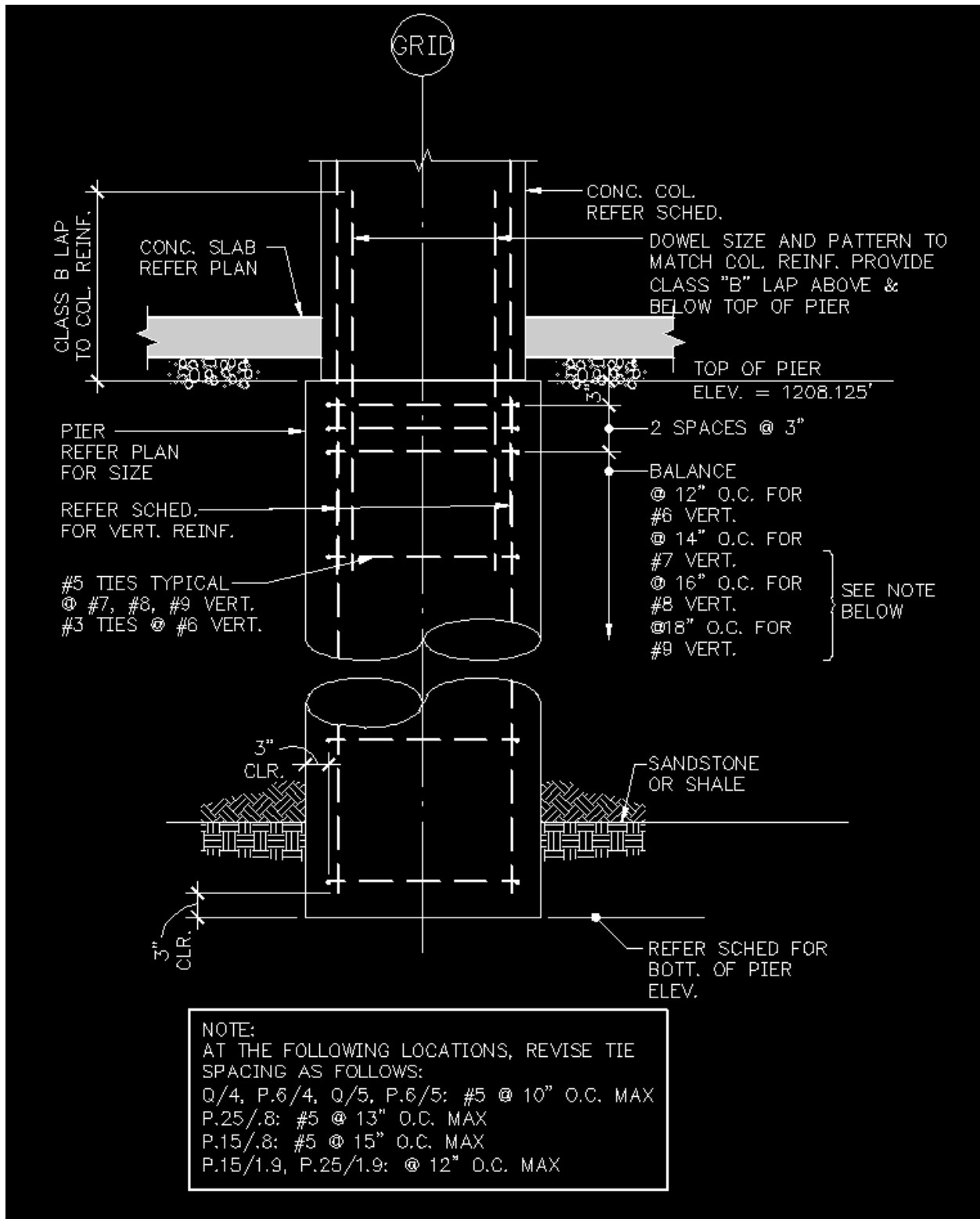

Figure F. Typical Pier Detail

The spread footings are designed to transfer the load from a column or wall over a larger area so the soil can resist the loading without significant settling. The footings are made of 4'-6" deep cast-in-place reinforced concrete. 21 #11 bars are used on both the top and bottom to resist the tensile forces created by the column. Since the footings are relatively short in length, 90° hooks are required on each end in order to get a full development length. #5 stirrups are used at 24" on center to resist the shear forces. Figure G shows a typical footing detail.

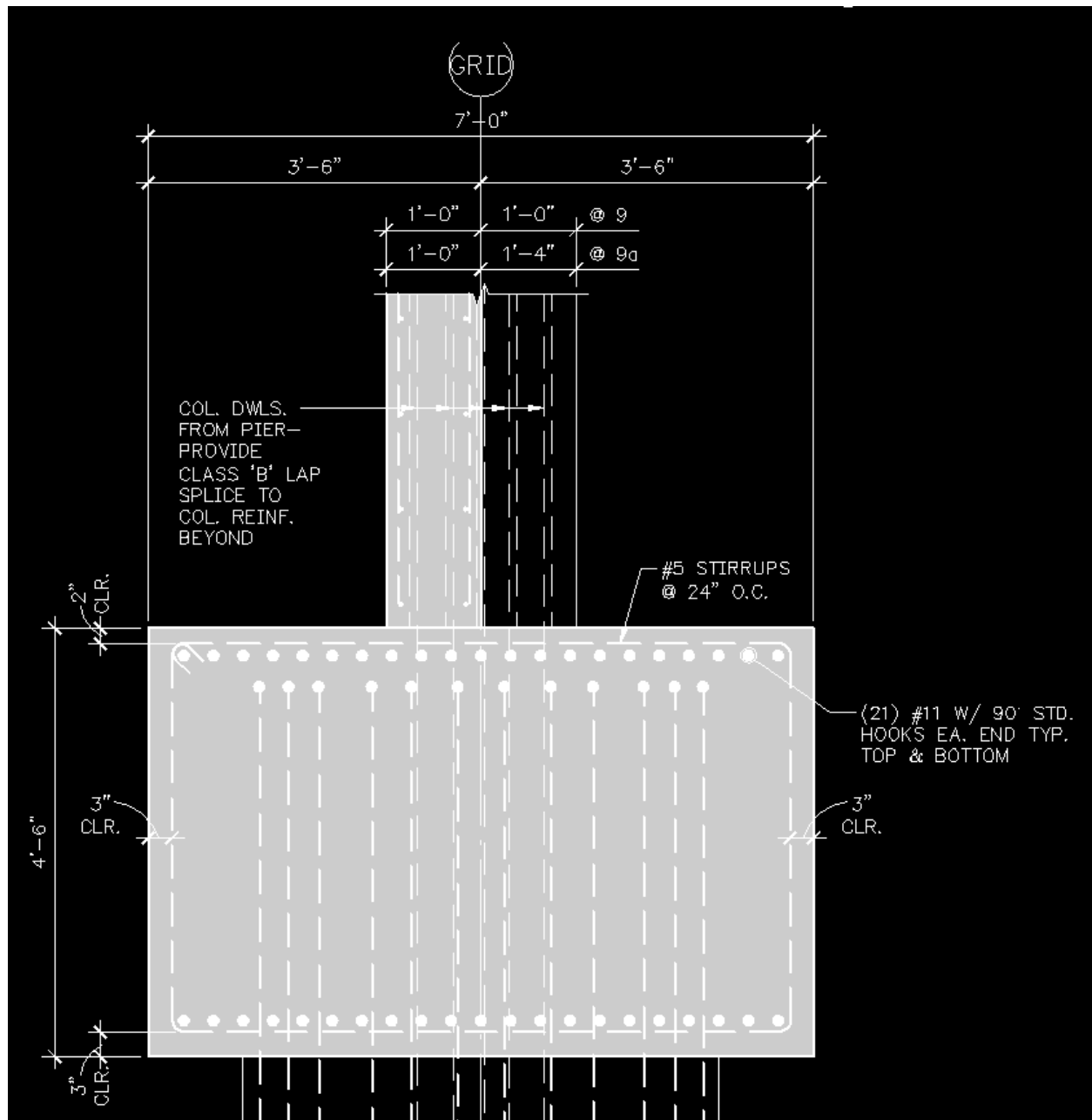

Figure G. Typical Footing Detail

Typical Bay

A typical bay consists of four columns situated in a square as shown in Figure H. A flat slab spans between the columns with drop panels. A flat slab refers to a slab that is supported by columns and drop panels and not by beams. The reinforced slab is divided into the column strips, which span between the columns, and the middle strips, which are at the interior of the bay. The bay also consists of drop panels located below the slab at the four columns. The purpose of the drop panel is to provide extra thickness to control the negative moment created by the load case and to resist shear. Without the drop panels, the slab would have to be thicker in order to resist the distributed load case. As a result, the drop panels use less material and therefore save money on construction costs.

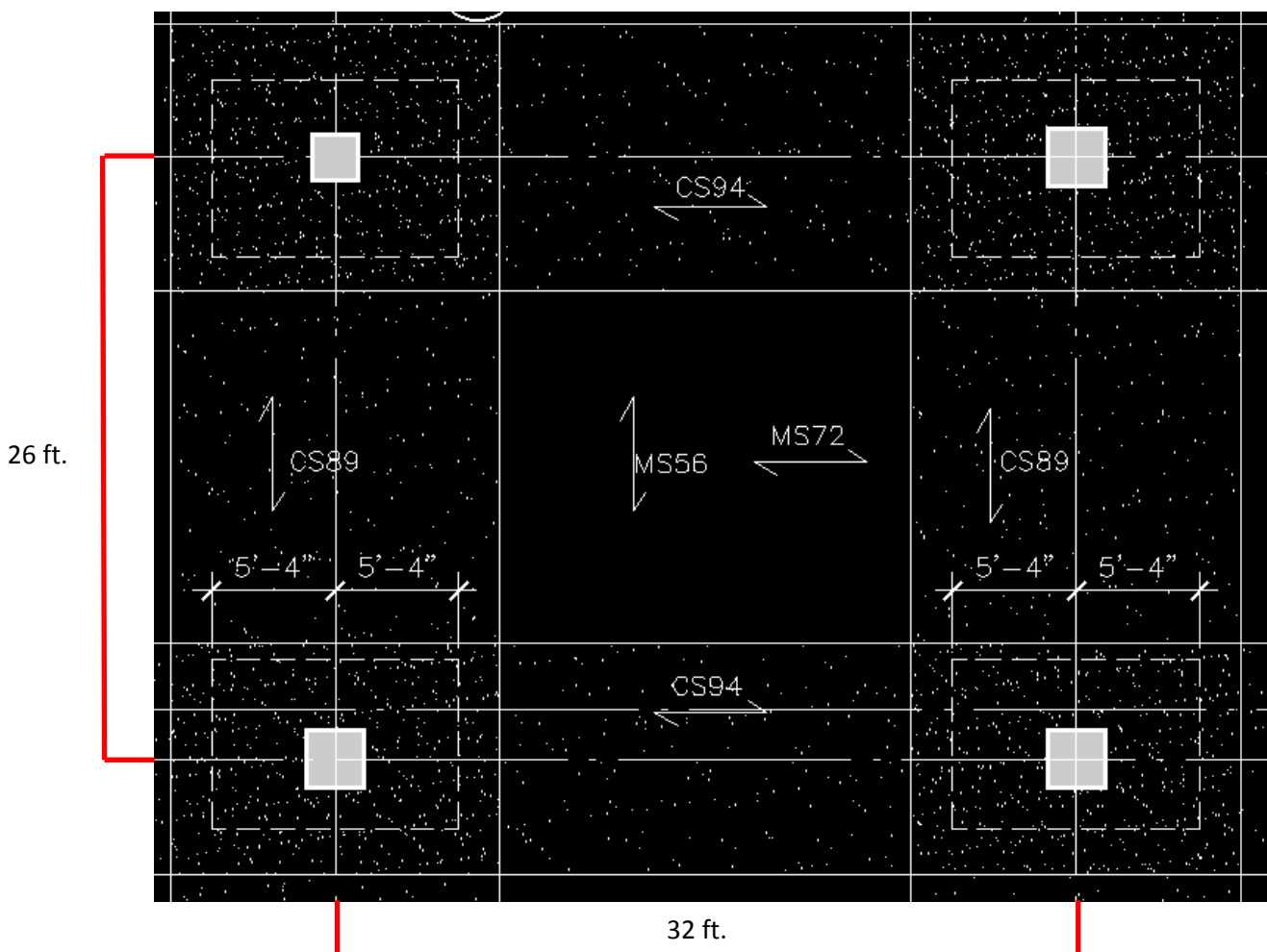

Figure H. Typical Bay Plan

The strips designated with a C are column strips and those designated with an M are middle strips.

Columns

The columns are generally designed to handle the gravity loads of the structure. The columns for this particular building vary in size from 20" x 20" to 30" x 30" with most in the range of 22" x 22" and 28" x 28". As the building increases in height, the columns decrease slightly in size due to the decrease in the loading. Typically the columns are square with the exception of the columns facing the western exterior curtain wall which are circular. The typical concrete strength for the columns is 7000 psi. The reinforcement varies depending on the column size and orientation but most use #6 bars. Most columns require #3 ties at 12" on center. The reinforcement is arranged around the perimeter of the column with a typical 2" offset from the face of the column. This is called clear cover and it is to ensure that enough concrete surrounds the bar to allow the maximum bonding strength between the steel and concrete. ACI 318-02 states that the minimum cover for a column is 1 1/2"; however, since the parking garage columns are exposed to the weather, the code states that the minimum cover is now 2". The designers chose to use the 2" cover for the rest of the building for constructability. Refer to Figure I for a typical column section. The vertical bars are spliced together with a class B lap splice from the ACI 318-02 code, which refers to a splice where a percentage of the development length of a bar overlaps another bar. This overlap allows for continuous reinforcement the total height of the column. Due to the helicopter pad on the roof, six of the columns are raised above the roof level and are larger in size on account of the larger load.

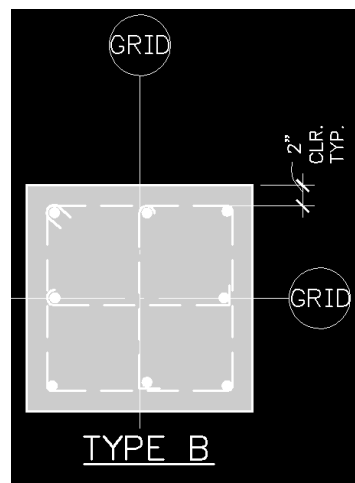

Figure I. Typical Column Section

Beams

The majority of the beams are located at the exterior of the building. The beams are mainly rectangular in shape and have a range of sizes from 16" x 60" to 36" x 24". Most beams are designed with a concrete strength of 5000 psi. All beams have top reinforcement as well as bottom reinforcement to resist the positive and negative moments resulting from the distributed loading. However, a portion of the beams also contain middle bars. The typical bar size is #9 but #7 is also used. #4 and #3 stirrups are used for the shear reinforcement with a clear cover of 1 1/2". Refer to Figure J for a typical beam section.

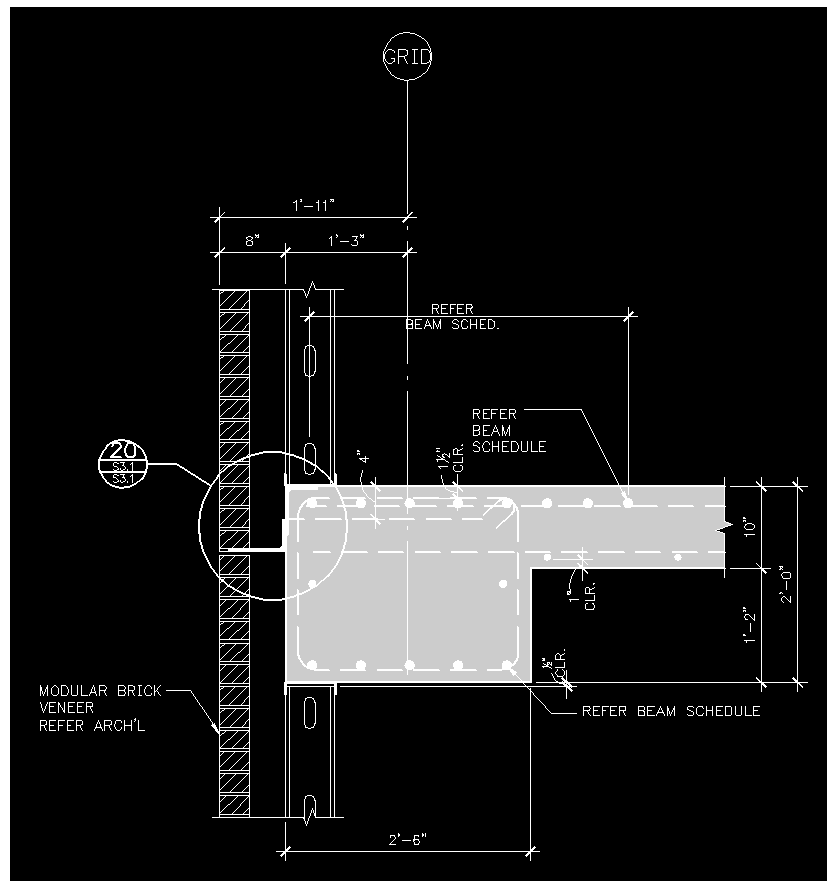

Figure J. Typical Beam Section

Slabs

In order for the slabs to resist the dead and live loading, they must be reinforced. They are divided into column strips and middle strips, as shown in figure G, with different reinforcing in each. The column strip is located at locations between the columns. Since

the column strips are significantly thinner than beams, a drop panel is used to carry the extra moment that the slab cannot. The column strips have reinforcing in both directions. The slab thicknesses for the column strip ranges from 10 inches to 12 inches. The 10 inch slab is used in the second through twelfth floors and the roof. The 12 inch slab is used for the parking garage located on the first floor. These thicknesses do not include the drop panels. The reinforcement is typically placed on the top at column locations and on the bottom at mid span. Typically # 6 bars are used at 6" on center. On the other hand, the middle strips are designed differently. The middle strips have reinforcement spanning in two directions. The slab thickness for the middle strips is similar to the column strips in that they also range from 10 inches, for all floors not including the first floor, to 12 inches, for the first floor. The placement reinforcement is also similar to column strips in that the top reinforcement is located at the supports, while the bottom reinforcement is located at mid span. Typically #6 bars are used at 12" on center. All structural slabs have a concrete strength of 5000 psi and a typical clear cover of 1".

Lateral system

Since the building is a reinforced concrete structure, all of the connections between the columns are considered rigid. This means that the connection between the column and the beam has the ability to transfer a lateral load from the diaphragm to the column and into the ground. However, if the lateral loads are great enough, a separate system must be used to transfer the loads. This is called the Lateral Force Resisting System and it involves the use of shear walls, bracing, or moment frames to transfer the loads. The primary Lateral Force Resisting System for this building relies on the shear walls located in the elevator shafts, stairwells and some interior walls as shown in red in Figure K. Since a shear wall must be continuous from the roof to the foundation, they are typically placed in the elevator shafts or stairwells as shown in Figure L. The shear walls are typically one foot thick with #4 vertical and horizontal bars at 12" on center. They typically span between two columns, shown in Figure M, allowing the reinforcement of the shear wall to tie into the column, making the system stiffer.

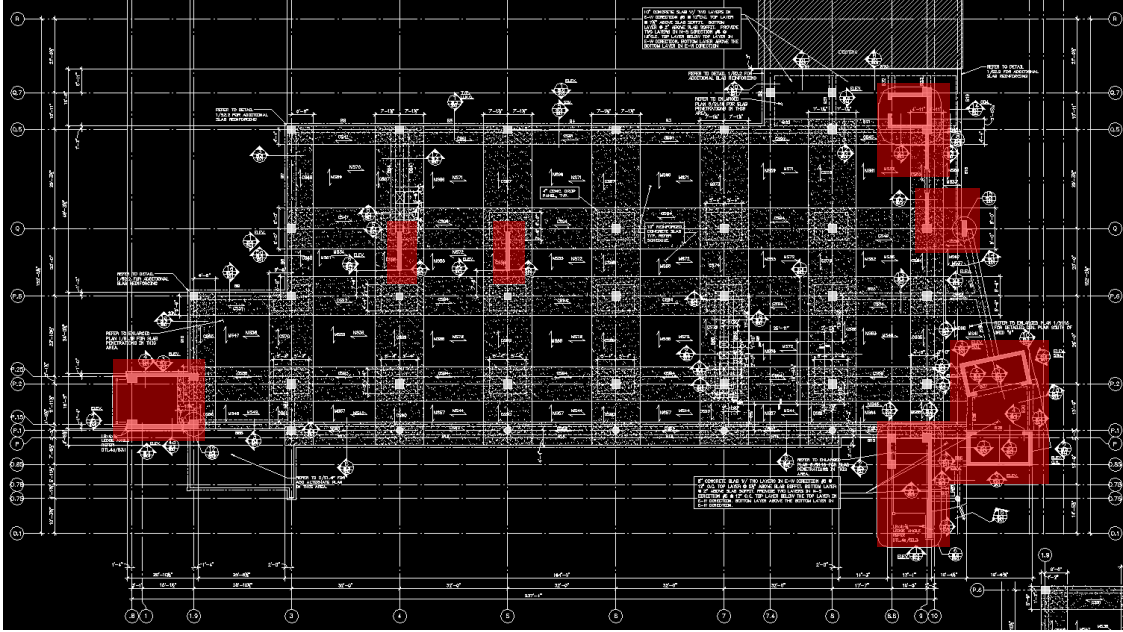

Figure K. Floor plan highlighting shear wall locations.

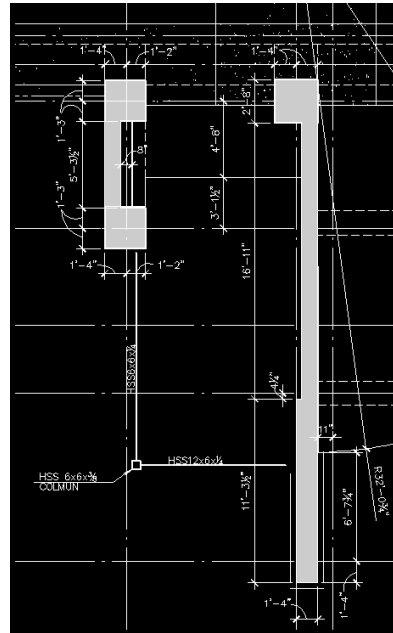
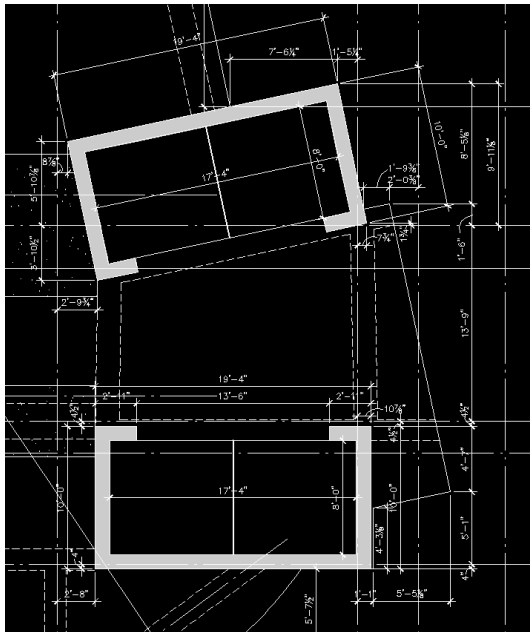

Figure L. Left – Shear wall located at elevator shafts. Right – Shear wall located at stairwells.

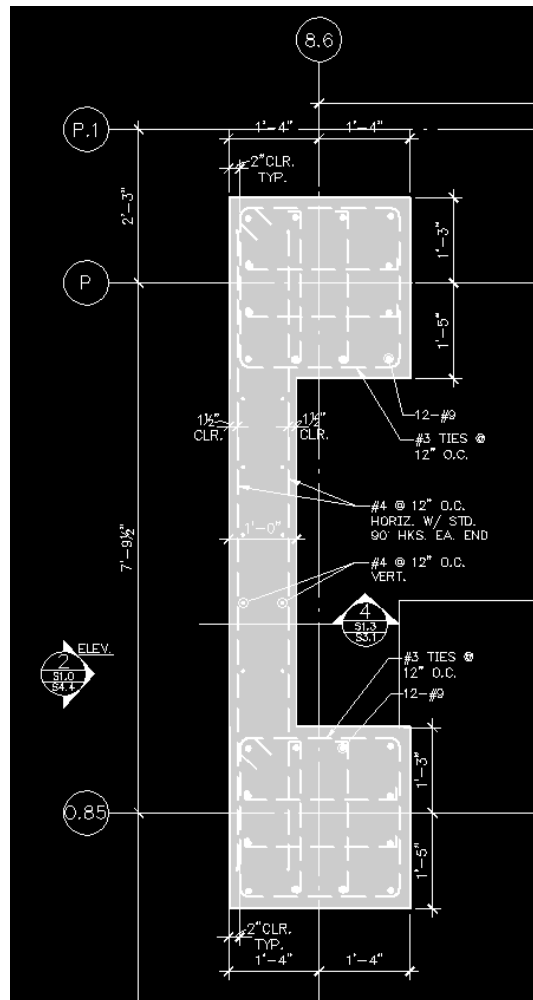

Figure M. Typical Shear Wall Section

Reinforcement

The placement of reinforcement is key to a sturdy concrete building. Since concrete becomes brittle in tension, steel reinforcement is needed to carry the extra tensile forces. The bars are placed at high tensile stress locations in order to prevent the concrete from cracking. In the case of a beam or slab, the reinforcement is placed at the top towards the supports. This is where a negative moment occurs and therefore where higher tensile stresses occur. Reinforcement is located at the bottom towards the mid span of the beam or slab to provide extra tension capacity where a positive moment occurs. The location of the reinforcement is shown in Figure J. Columns, on the other hand, are reinforced around the perimeter as shown in Figure I. Columns are reinforced this way to provide tension capacity during lateral loads such as wind or seismic. The reinforcement in columns must be continuous. When a bar is not long enough to span a certain length, it

is spliced together to form a continuous bond. These splices can either be mechanical splices or non-mechanical splices such as the class “B” splice mentioned in the column. For non-mechanical splices, the bars must overlap each other a distance relative to the development length to achieve the desired load transfer. Stirrups are used to prevent shear and torsion. Stirrups are smaller bars that encase the horizontal or vertical reinforcement as shown in figure I for beams and figure H for columns. The spacing is critical to prevent failure under torsional conditions. The reinforcement must also have a certain length embedded in the concrete to create a strong bond between the concrete and the steel. This length is called development length. If development length cannot be achieved with a shorter reinforcement span, then special methods must be used, such as bending the bar to form a hook, to achieve the desired length.

Structural Design Alternative

Since the Oklahoma University Children’s Medical Office Building is constructed using a two way concrete system, the construction process is extremely long to allow the concrete to cure. This adds additional costs to the project, making the job more expensive. Concrete is a labor intensive material meaning that the installation requires many skilled labors to construct the forms, set the reinforcement, and leveling the concrete. The high amount of labor adds to the overall project costs, making concrete a relatively expensive material. The proposed thesis will be a redesign of the building structure using steel. The gravity system will consist of a composite steel system with composite decking. The lateral system will consist of steel braced frames located at existing shear wall locations. A redesign using steel instead of concrete should reduce construction time resulting in lower costs to the owner. Steel in comparison with concrete is not as labor intensive. Steel does not require the level of skilled labor as concrete does to install unless complicated field welds are used. As part of the proposal, bolted or factory welded connections will be used where ever possible. These connections will be used to speed up the construction process and reduce the costs as field welds become expensive and time consuming due to the skilled labor and precision of the weld.

Proposed Solution

The solution consists of a redesign of the building using a composite steel system with composite decking as shown in the layout of the typical bay in Figure N. The floor will consist of 2VLI 20 gage deck obtained from the Vulcraft deck catalog. A concrete topping of 4 ½” with normal weight concrete will be used to achieve a two hour fire rating without having to fireproof the deck. A spacing of 8’ – 8” will be used for the beams. This spacing allows the deck to be unshored during construction which reduces costs. The beams will consist of W16x26 wide flanges with twelve shear studs per beam. The girders will primarily be W18x35 wide flanges with 26 shear studs per girder. Due to the Oklahoma University Children’s Medical Office Building having slightly different spans per bay, the size of the members will either decrease or

increase depending on the length of the span. The floor to floor height will typically be twelve feet with the height not exceeding fourteen feet for the first story. The floor to floor heights will not change from the existing design. The columns will be sized based on the existing floor to floor heights. Since this building has a parking garage located on the first and second floor, the exposed steel must be protected from the weather. The proposed solution involves encasing the steel in concrete to prevent any erosion from the weather.

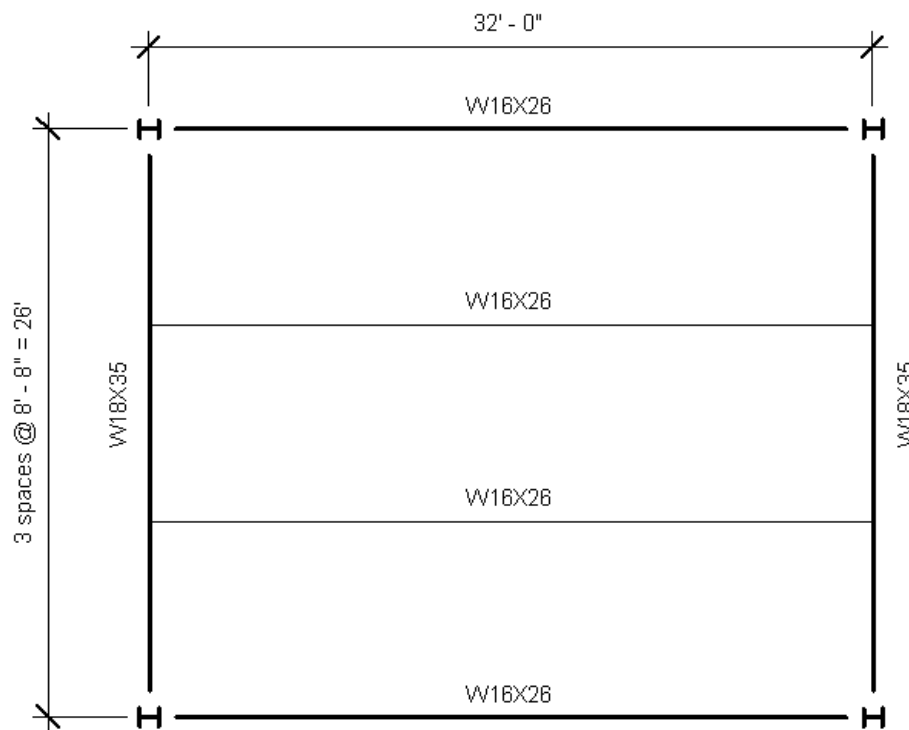

Figure N. Proposed Layout for the Typical Bay

The lateral resisting system will be steel braced frames located in the existing elevator shafts and stair wells. They will also be located at existing shear wall locations to minimize the impact on the architectural floor plan. The braced frame locations are shown on the floor plan in Figure O. Concentric X braced frames will be used in locations that do not require openings. These locations include the sides of elevator shafts and stairwells that do not require a door, shown in red in Figure O. Where there will need to be an opening, eccentric knee braces will be used. These areas include sides of elevator shafts or stairwells that require a door opening, shown in blue in Figure O. In the event that the braced frames will be insufficient to carry the lateral load due to their lower stiffness, additional knee braces will be provided on the exterior wall faces with brick cladding to minimize the impact on the architectural floor plan and the day lighting provided by the windows. These potential locations will be shown in green in Figure O.

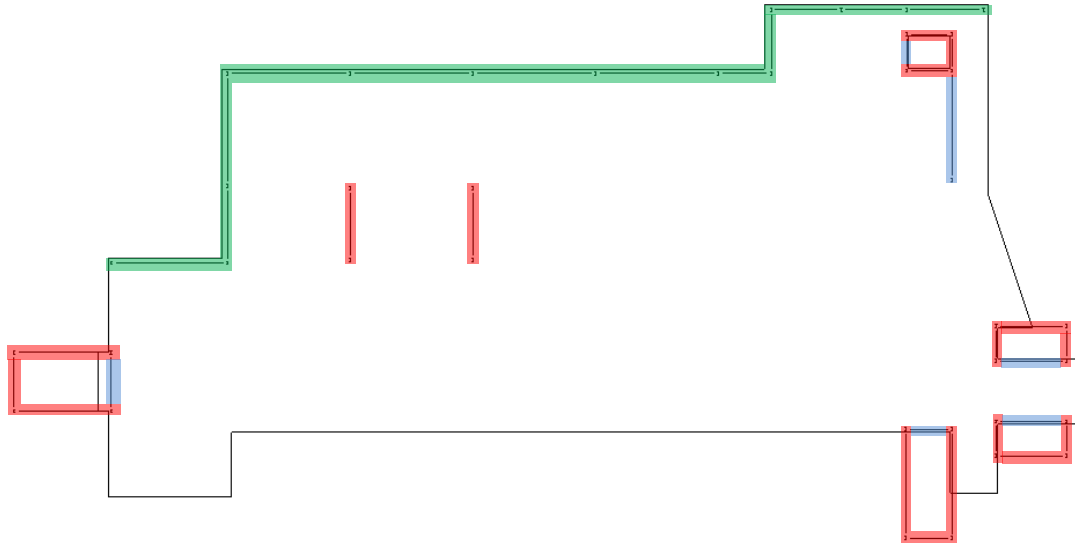

Figure O. Braced Frame Locations

With the redesign of the building, the most current codes will be used. The 2009 IBC code will be used to determine the occupancy live loads. ASCE 7-10 will be used as a guide to determine the wind and seismic loads.

Solution Method

The deck will be designed according to the composite deck specifications laid out by the Vulcraft Deck Catalog. Composite three span decking will be used with topping that will achieve a two hour fire rating. The beams will be spaced according to the unshored maximum clear span of the deck. The trial beam sizes will be designed with composite action based on AISC 14th edition Table 3-19. There are several assumptions that must be determined in order for this analysis. The concrete strength will be assumed to 4000 psi. The deck is assumed to be perpendicular with the beams. The studs are assumed to be 3/4" in diameter with one stud per foot and one weak stud per rib. Several checks must be completed as part of the analysis. The unshored strength, the wet concrete deflection, and the live load deflection must all be check to determine if the beam can pass the construction and service requirements. The trial girder sizes will be determined using the same method as determining the beam trial sizes. The assumptions are the same except instead of the deck being perpendicular to the girders; the deck will be parallel to the girders. Once the trial sizes are calculated, the sizes will be input into Ram software to determine the final sizes. The lateral system will also be analyzed used Ram software.

Tasks and Tools

I. Composite Steel with Composite Deck Alternative

Task 1. Determine loads for the building

- a) Determine the dead loads of the building
- b) Determine the live loads of the building based on the 2009 IBC code
- c) Determine the wind loads based on the ASCE 7-10 code
- d) Determine the seismic loads based on the ASCE 7-10 code

Task 2. Establish trial member sizes

- a) Determine the deck size based on an unshored condition using the Vulcraft Deck Catalog
- b) Determine the beam sizes based on the unshored spacing of the deck and using the AISC 14th edition Table 3-19
- c) Determine the girder sizes based on the beam sizes and using the AISC 14th edition Table 3-19
- d) Determine the column sizes based on the story loads and the Effective Length Method outlined in the AISC 14th edition Appendix 7.2

Task 3. Finalize the initial frame analysis

- a) Follow tutorials and online forums to learn RAM software
- b) Input the trial sizes into the program to determine the final member sizes
- c) Perform a cost analysis using the Means Construction Cost Data to determine the most economical balance between the deck size, beam spacing, and beam size
- d) Perform a vibration analysis and determine if the members are sufficient enough to handle the vibration requirements set by the 2009 IBC code

Task 4. Finalize the final frame analysis

- a) Based on the results determined from Task 3, redesign the structural system to find the most economical balance between the deck size, beam spacing, and beam size. This may require several iterations to find the most economical solution.

Task 5. Initial lateral system analysis

- a) Input the brace frames into the RAM software
- b) Determine the if the braced frames will be sufficient to carry the lateral load

Task 6. Final lateral system analysis

- a) Add additional braced frames if necessary and input them into the RAM software

Task 7. Cost analysis and schedule breadth

- a) Perform an in-depth cost analysis using the Means Building Construction Cost Data
- b) Compare this value with the current cost of the building to determine if the proposed solution is more cost effective.
- c) Analyze the schedule impacts of the proposed system and compare this with the current schedule

Task 8. Green roof addition breadth

- a) Research available foliage that could be used on the roof based on local foliage
- b) Determine an appropriate layout of plants that maximizes the amount heat reduced on the building

Task 9. Write report and final power point presentation

Timetable

Proposed Thesis Semester Schedule		January 2013 - April 2013		13-Jan-14	20-Jan-14	27-Jan-14	3-Feb-14	10-Feb-14	17-Feb-14	24-Feb-14	3-Mar-14	10-Mar-14	17-Mar-14	24-Mar-14	31-Mar-14	9-Apr-14	
Jonathan Ebersole				Milestone 1 - 2/24/2014		Milestone 2 - 3/14/2014						S p r i n g		Milestone 3 - 4/9/2014			
Structural Option				Task 1: Determine the Loads		Task 2: Establish Trial Member Sizes		Task 3: Learn RAM and Input Trial Members		Task 4: Finalize The Gravity System		Task 5: Initial Lateral Analysis Task 6: Finalize the Lateral System		Task 7: Breadth 1		Task 8: Breadth 2	
Dr. Hanagan												B r e a k				Task 9: Write Report and Power Point	

Breadth Topics

Due to the proposed change of material, the first proposed breadth is a detailed cost analysis and schedule impacts of the proposed steel system. Since the material will be changed from concrete to steel, the costs for labor should decrease reducing the overall project costs. The construction time will be decreased due to the material change. The time it takes for the concrete to cure dramatically increases construction times. With using steel as the structural material, these times can be greatly reduced saving money.

The second breadth will be the addition of an extensive green roof. With the addition of the green roof, this will potentially reduce the heat island effect of the building. The green roof also has the potential to clean the air by filtering pollutants such as carbon dioxide. This will potentially reduce the heating and cooling cost of the building. An extensive green roof will be used instead of an intensive green roof due to the lower initial costs, lower maintenance costs, and lower roof loads. Research will be conducted to use local plants to reduce the amount of maintenance. The down side of the green roof addition will be higher initial costs and additional loads which will have to be accounted in the load calculations.

Conclusion

The Oklahoma University Children's Medical Office Building is a reinforced cast-in-place concrete building that uses a two way flat slab system with drop panels. The perimeter beams provide additional support to hold the exterior brick and glass façade. The lateral system uses cast-in-place reinforced concrete shear walls to transfer the wind and seismic loads to the foundation. The proposed redesign of the structural system will be a composite steel system with composite decking. The lateral system will consist of braced frames at existing shear wall locations. Since the building will be redesigned using steel, a vibrations analysis will need to be conducted to account for the reduction of mass. One breadth will consist of an in-depth cost and schedule analysis and comparison with the existing system. The other breadth will consist of a green roof addition and its impact on the buildings heating and cooling costs.